

# THOMPSON MEAT MACHINERY

*Frozen Block Pre Breaker*



**“THOMPSON TOUGH”**

**LEADING AUSTRALIAN MANUFACTURERS OF MEAT PROCESSING MACHINERY**

# THOMPSON FROZEN BLOCK PRE BREAKER

The **THOMPSON FROZEN BLOCK PRE BREAKER** is designed to break up hard and frozen food blocks including meat and dairy products **WITHOUT DESTROYING THE TEXTURE OF THE PRODUCT, ELIMINATING THE INCONSISTENTLY SIZED PARTICLES AND PRODUCT EMULSIFICATION.**

The Thompson Frozen Block Pre Breaker can take any **FROZEN PRODUCT WITHOUT THAWING FROM -18°C TO -3°C SAVING OPERATOR'S VALUABLE TIME AND ENERGY.** The blocks can be processed within a remarkable 4 seconds to produce an **EXTRAORDINARY PRODUCTION OF UP TO 8 TONNE PER HOUR.** Maximum output of the Pre Breaker is ensured by the **HIGH CUTTING SPEED** of the rotor type blade mechanisms. The frozen blocks are drawn to the slow speed rotor blades with high torque cutting forces **ACHIEVING EXCEPTIONAL PRODUCTION OUTPUT RATE.**

The frozen meat blocks are **EASY TO LOAD INTO THE CUTTING AREA,** where they are transformed by sharp blades into slices or with cross blades into smaller cube pieces. It is **SIMPLE AND SAFE TO OPERATE.**

The **THOMPSON FROZEN BLOCK PRE BREAKER** discharges product into 200L tote bins, various size tubs or onto conveyor for continuous feeding into Thompson range of Mixer Mincers for further processing. **20 TONNE PER HOUR PRODUCTION OUTPUT** can be achieved if continually conveyor fed.

The **ROBUST AND RELIABLE BUILT** quality means **LOW MAINTENANCE AND OPERATING COSTS** provides years of trouble-free operation.

## FEATURES OF THE FROZEN BLOCK PRE BREAKER:

- **HIGH OUTPUT** is ensured by the high cutting speed of the rotor type blade mechanism;
- Design of the Pre Breaking Cutting System provides **HIGH INTEGRITY OF LARGE PIECES OF MEAT** for further processing with **REDUCED VIOLATION OF THE STRUCTURE OF FROZEN MEAT.**
- Pre-breaking product by drawing frozen blocks with cutting forces to the rotor blades;
- **EASY MAINTENANCE, RELIABILITY** and **LOW OPERATING COSTS.**
- **EXCEPTIONAL QUIET OPERATION** when compared with Frozen Block Flaker

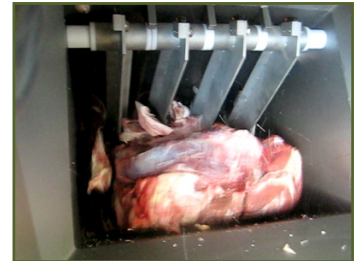

Intake Chute



High integrity of large pieces of processed mea

## THOMPSON FROZEN BLOCK PRE BREAKER SPECIFICATIONS:

Product Performance	
Production Capacity	8,000kg/h
Weight of Cut Pieces	100g – 450g
Minimum Product Block Temperature	Minus 15°C
Dimensions	
Intake Chute Height (from floor)	1,300mm
Intake Chute Depth	270mm
Dimensions of Blocks Fed (LxWxH)	600mm x 400mm x 270mm
Discharge Height	700mm
Floor Area (without service zone)	1.6m <sup>2</sup>
Overall Dimensions (LxWxH)	1,330mm x 1,030mm x 1,630mm
Net Machine Weight	760kg
Motor / Power Supply*	
Motor	15kW
Power Supply	63 Amps
Full Load Current	30 Amps
Shipping Dimensions	
Shipping Weight	900kg
Shipping Dimension	1,480mm x 1,220mm x 1,795mm

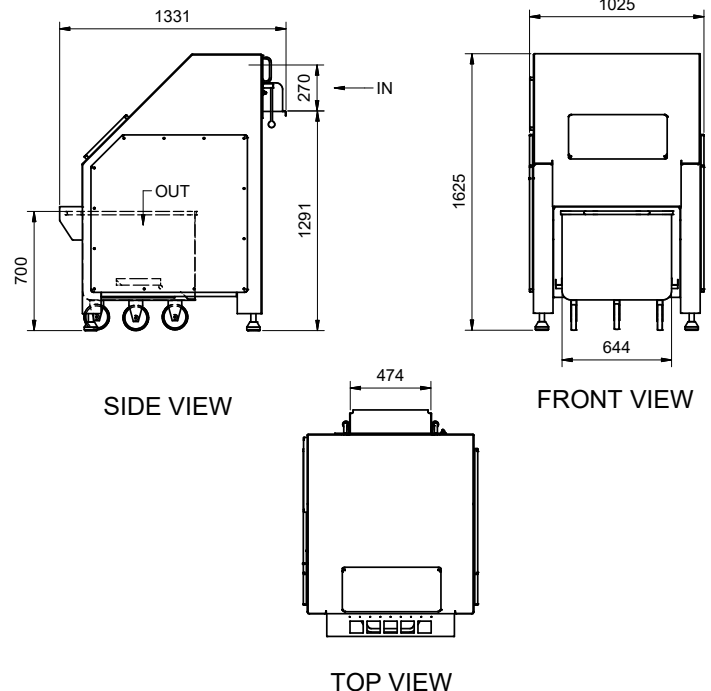

\*Machine power to be fitted with a "D" curve motor start circuit breaker.  
 Technical data is to be used as a guide only and is subject to change without notice.  
 Dimensions and weights may vary in the course of development.

*Manufactured in accordance with Australian Standards and Regulations*

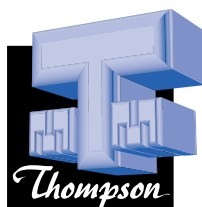

**THOMPSON MEAT MACHINERY PTY LTD**

134 MAGNESIUM DRIVE, CRESTMEAD, QLD AUSTRALIA 4132

PHONE +61 7 3803 6643 — FAX +61 7 3803 6635

EMAIL [sales@tmach.com.au](mailto:sales@tmach.com.au) — WEB SITE [www.tmach.com.au](http://www.tmach.com.au)